



SERVICE-ORIENTED MODELING FRAMEWORK™ (SOMF™)

VERSION 2.1



SERVICE-ORIENTED CONCEPTUALIZATION MODEL LANGUAGE SPECIFICATIONS

TABLE OF CONTENTS

INTRODUCTION.....	3
About The Service-Oriented Modeling Framework (SOMF).....	4
About The Service-Oriented Conceptualization Model.....	6
NOTATION SECTION.....	7
Conceptual Assets.....	8
Conceptual Association Connectors.....	10
Conceptual Attribution Model and Conceptual Decision Tree Building Blocks.....	12
Modeling Spaces.....	13
EXAMPLES SECTION.....	14
Attribution Model Diagram.....	15
Decision Tree Diagram.....	16
Conceptual Association Diagram.....	18

INTRODUCTION

ABOUT THE SERVICE-ORIENTED MODELING FRAMEWORK (SOMF)

The service-oriented era has begun. New technologies have emerged to support the "service" notion that signifies, today more than ever, a shift in modern computing whose driving aspects are business imperatives and innovative technological implementations. The service paradigm is not a new concept; however, it emboldens the business perspective of every software development life cycle. Furthermore, unlike the object-oriented approach, which is founded to support modeling of object-based programming languages, the service-oriented modeling framework embodies distinct terminology to foster loose coupling of software assets, reuse of software components, acceleration of time-to-market, reduction of organizational expenditure, and more.

SUPPORTING THE SERVICE-ORIENTED MODELING NOTION

Thus, to support service-oriented modeling activities, SOMF depicts the term "service" as a holistic entity that may encapsulate business requirements, and from a technological perspective, is identified with a software component. This organizational software entity, namely a "service" that is subject to modeling activities, may be any software construct that the enterprise owns, such as an application, software system, system software, Web service, software library, store procedure, database, business process, enterprise service bus, object, cloud computing service, and more.

SO WHAT IS SOMF?

SOMF is a model-driven engineering methodology whose discipline-specific modeling language and best practices focus on software design and distinct architecture activities employed during stages of the software development life cycle. Moreover, architects, analysts, modelers, developers, and managers employ SOMF standalone capabilities or mix them with other industry standard modeling languages to enrich the language syntax, set software development priorities during life cycle stages, and enhance the 360° software implementation view.

SOMF DISCIPLINES AND MODELS

SOMF offers a 360° view of any software development life cycle, starting at the conceptualization phase, supporting design and architecture activities, and extending modeling best practices for service operations in a production environment. To achieve these underpinning milestones, six distinct software development disciplines offer corresponding models whose language notation guide practitioners design, architect, and support a service ecosystem:

1. Service-Oriented Conceptualization Model
2. Service-Oriented Discovery and Analysis Model
3. Service-Oriented Business Integration Model
4. Service-Oriented Logical Design Model
5. Service-Oriented Software Architecture Model
6. Cloud Computing Toolbox Model

MODELING GENERATIONS

SOMF diagrams support three chief modeling generations, each of which shows a different time perspective of a software life cycle. These views help practitioners depict business and architectural decisions made at any time during the life span of a software product:

1. *Used-to-Be*. Design and architecture *past state* of a software product and its related environment that were deployed, configured, and operated in production
2. *As-Is*. Design and architecture *current state* of a software product and its corresponding environment that are being operated in production
3. *To-Be*: Design and architecture *future state* of a software product and its associated environment that will be deployed, configured, and operated in production

ABOUT THE SERVICE-ORIENTED CONCEPTUALIZATION MODEL

This specifications paper focuses on the Service-Oriented Conceptualization Model language notation whose capabilities assist practitioners to transform business and technological ideas and requirements into software concepts. Furthermore, the conceptualization model not only offers a generalization process that enables the discovery of new services for a project, but also helps in scoping a development effort and identifying solutions for organizational concerns.

Consider the chief benefits of the Service-Oriented Conceptualization Model language:

- Discovering service concepts that stem from ideas and requirements
- Defining services and software components for a project
- Founding organizational core entities
- Addressing software separation-of-concern challenges
- Instituting an organizational common design and architecture language and vocabulary
- Developing service taxonomies for projects or organizational architecture purposes
- Establishing relationships between services and software components
- Defining service attributes and business rules

NOTATION SECTION

CONCEPTUAL ASSETS

The conceptual assets group, illustrated in Figure 1, includes seven different modeling entities, concepts and ideas that drive the discovery of future software implementations. These implementations are typically services, software components, applications, clouds of services, consumers, or processes that offer solutions. Each of these discoveries may materialize later into tangible software constructs during the construction phase of the software development life cycle.

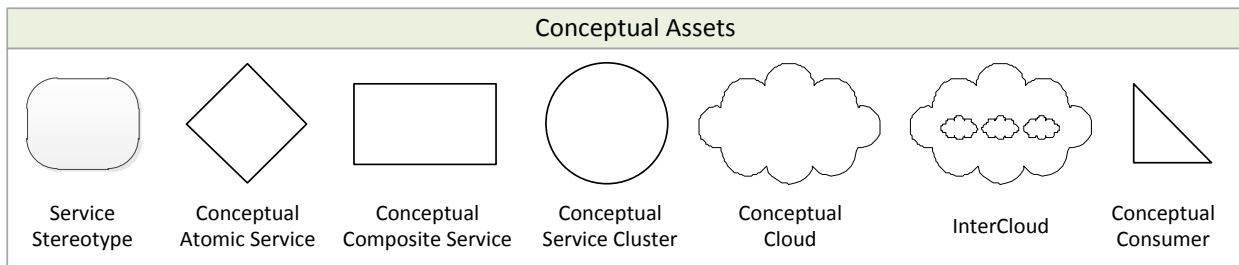

FIGURE 1: CONCEPTUAL ASSETS

- *Service Stereotype.* A generic conceptual service that does not identify any particular service structure pattern
- *Conceptual Atomic Service.* A fine-grained service that is impractical to decompose because of its suggested limited capabilities or processes
- *Conceptual Composite Service.* A coarse-grained service comprised of internal fine-grained atomic or composite services, forming an internal hierarchical parent/child structure
- *Conceptual Service Cluster.* Association of services grouped by related business or technical processes that collaborate to offer solutions

- *Conceptual Cloud.* Represents a collection of conceptual services in three different categories: Software as Service (SaaS), Platform as Service (PaaS), and Infrastructure as Service (IaaS). Additional types can be added on demand
- *InterCloud.* Represents the term “cloud-of- clouds.” A superior cloud that identifies a group of related clouds, working together to offer collaborative solutions
- *Conceptual Consumer.* Any conceptual entity that is identified with service consumption activities. This definition may include consuming applications or services

CONCEPTUAL ASSOCIATION CONNECTORS

To relate the conceptual assets discussed in the previous section, use the depicted connectors in Figure 2. These linking connectors identify business or technical associations between conceptual service providers and their corresponding consumers. In addition, these connectors can help establish relationship patterns that may influence the design of message exchange paths later during the software development life cycle.

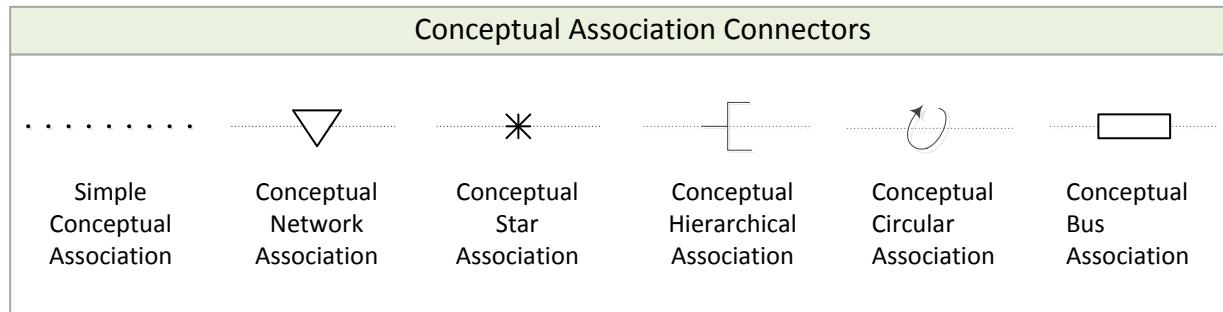

FIGURE 2: CONCEPTUAL ASSOCIATION CONNECTORS

- *Simple Conceptual Association Connector.* A conceptual relationship connector that links conceptual assets with no specific or identifiable association pattern
- *Conceptual Network Association Connector.* A many-to-many association pattern that links two or more service providers and consumers
- *Conceptual Star Association Connector.* Related service consumers and providers arranged in a star pattern, in which the dominant conceptual entity is positioned in the center of the star and its subordinate services or consumers occupy the star arms
- *Conceptual Hierarchical Association Connector.* A hierarchical association formation in which parent conceptual services are linked to child services or consumers

- *Conceptual Circular Association Connector.* A depiction of a conceptual relationship pattern that is comprised of related services and consumers, arranged in a circular formation. The first member is linked to the last member of the chain
- *Conceptual Bus Association Connector.* Related service providers and consumers are linked by a central mediation entity

CONCEPTUAL ATTRIBUTION MODEL AND CONCEPTUAL DECISION TREE BUILDING BLOCKS

Use the elements provided in Figure 3 to construct a service attribution model and a conceptual decision tree to facilitate the discovery of conceptual services (see related examples in the Examples Section). An attribution model is a structure that is comprised of service attributes. This structure formation is influenced by business or technical requirements. On the other hand, the decision tree structure helps practitioners to discover conceptual services by combining attributes and business rules.

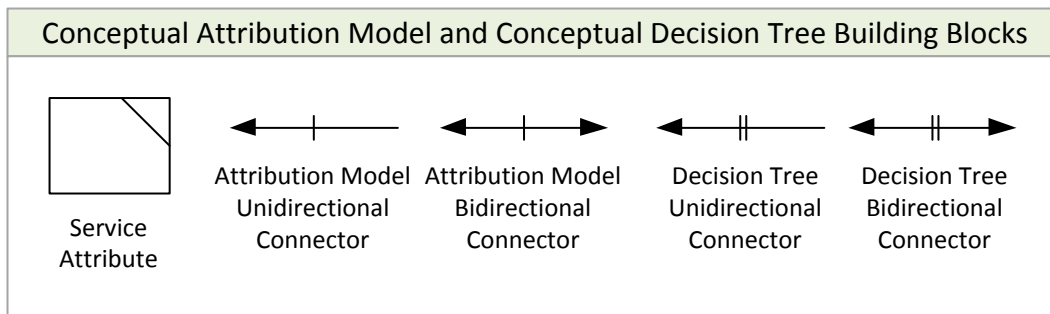

FIGURE 3: ATTRIBUTION MODEL AND CONCEPTUAL DECISION TREE BUILDING BLOCKS

- *Service Attribute.* A property that defines certain characteristics of a future service or software component
- *Attribution Model Unidirectional Connector.* A one-way connector that links a parent attribute with a child attribute in an attribution model structure
- *Attribution Model Bidirectional Connector.* A two-way connector that links a parent attribute with a child attribute in an attribution model structure
- *Decision Tree Unidirectional Connector.* A one-way connector that links a parent attribute to a child attribute in a decision tree structure
- *Decision Tree Bidirectional Connector.* A two-way connector that links a parent attribute to a child attribute in a decision tree structure

MODELING SPACES

A modeling space (illustrated in Figure 4) is a defined area in which modeling activities take place. This area also identifies boundaries of organizations, and containment scope of service clusters or cloud computing environments.

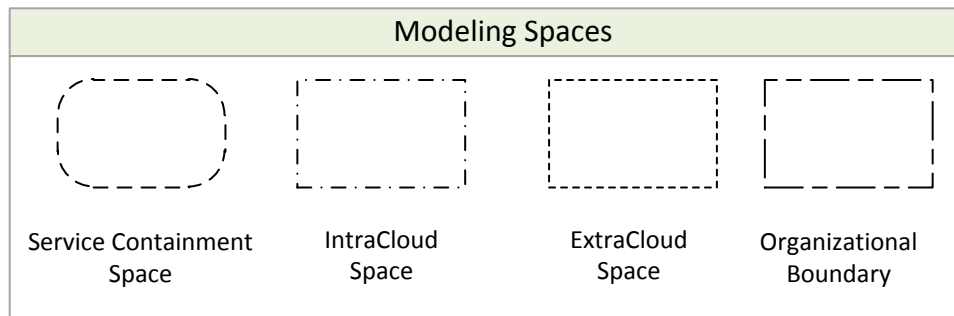

FIGURE 4: MODELING SPACES

- *Service Containment Space.* An area that identifies the aggregated child services contained in a parent composite service or service cluster. This space can also define collaboration of compounded services that are gathered to offer a solution
- *IntraCloud Space.* A modeling area that shows services that operate in a cloud
- *ExtraCloud Space.* A modeling area that depicts services that operate outside of a cloud
- *Organizational Boundary.* A computing area of an organization, such as a division, department, company, partner company, consumer, or community

EXAMPLES SECTION

ATTRIBUTION MODEL DIAGRAM

A structure of service attributes, derived from business or technical requirements, is arranged in a neural network formation to help practitioners select the most practical attributes for conceptual service discovery.

ATTRIBUTION MODEL DIAGRAM COMPONENTS (FIGURE 5)

- a. Service attributes: Return, Risk, Liquidity
- b. Connectors: Attribution Model Unidirectional

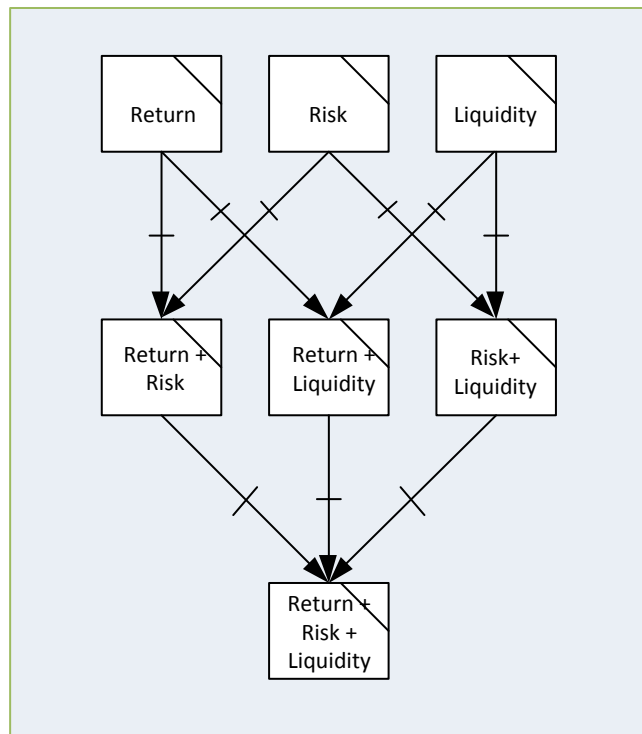

FIGURE 5: ATTRIBUTION MODEL DIAGRAM

DECISION TREE DIAGRAM

Practitioners use a decision tree diagram to define business rules, discover conceptual services, clouds of services, and service clusters. A decision tree can also assist with the establishment of service taxonomy.

DECISION TREE DIAGRAM COMPONENTS (FIGURE 6)

- Service attributes: High Risk, High Return, High Liquidity
- Connectors: Decision Tree Unidirectional
- Deriving service stereotypes: Public Equity, Private Equity, Junk Bond, Private Equity, Real Estate, CD, Long-Term Corporate Bond

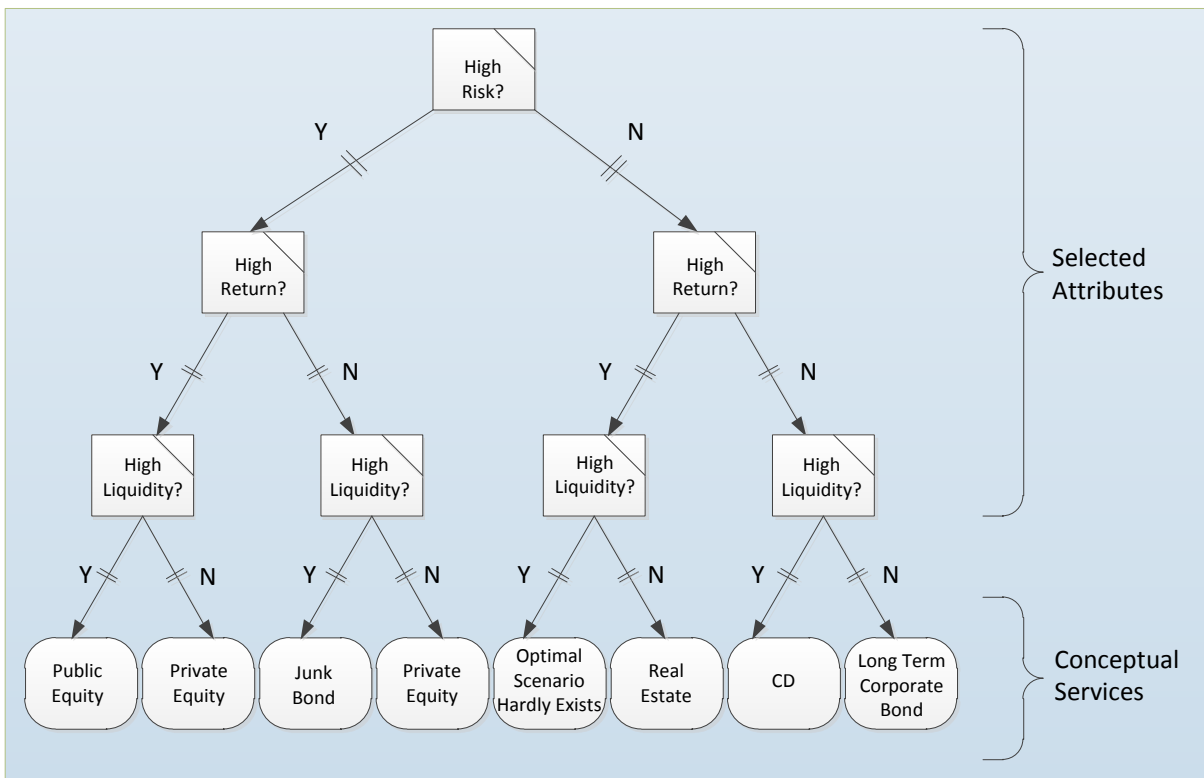

FIGURE 6: DECISION TREE DIAGRAM

DECISION TREE DIAGRAM COMPONENTS (FIGURE 7)

- a. Service attributes: Attr A, Attr B, Attr C
- b. Connectors: Decision Tree Unidirectional
- c. Deriving services: atomic service A-1, cloud of services CLO-1

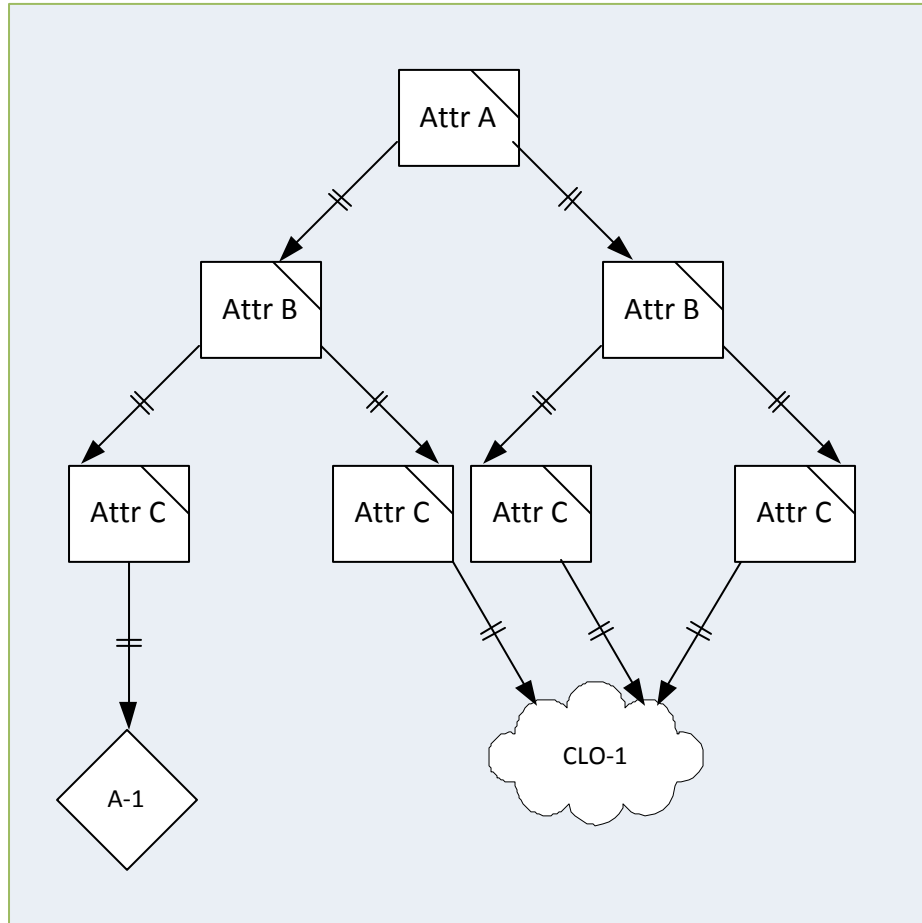

FIGURE 7: DECISION TREE DIAGRAM WITH CLOUD AND ATOMIC SERVICE DERIVATIONS

CONCEPTUAL ASSOCIATION DIAGRAM

A Conceptual Association Diagram illustrates the relationship between two or more conceptual services and consumers. The links between these conceptual entities can be depicted by using the Simple, Bus, Circular, Hierarchical, or Star association connectors.

CONCEPTUAL ASSOCIATION DIAGRAM COMPONENTS (FIGURE 8)

- a. Services: Service cluster CLU-1; atomic services A-1,A-2, and A-3; composite services CO-1 and CO-2
- b. Connectors: Conceptual Bus Association

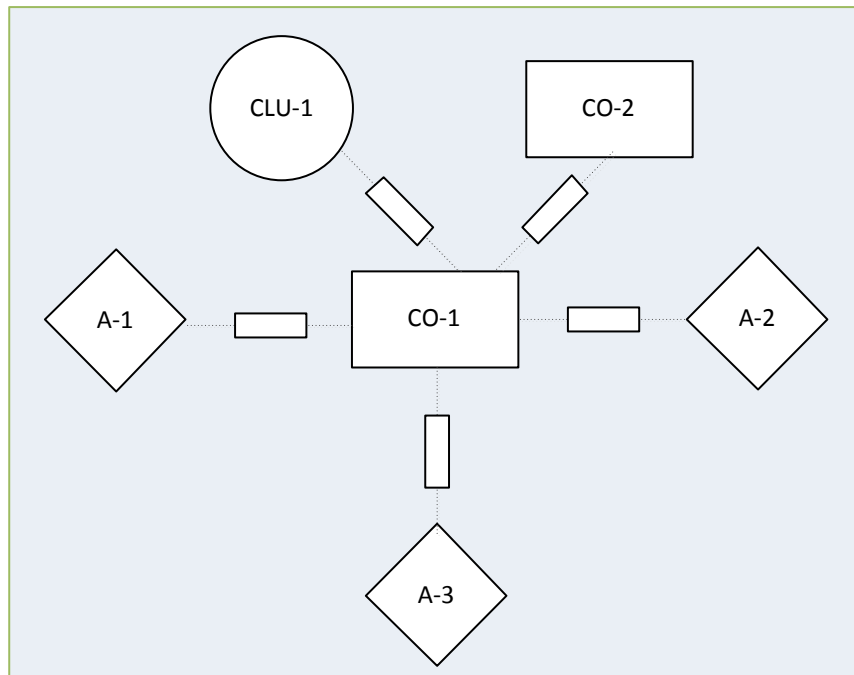

FIGURE 8: CONCEPTUAL ASSOCIATION DIAGRAM USING THE BUS PATTERN

CONCEPTUAL ASSOCIATION DIAGRAM COMPONENTS (FIGURE 9)

- a. Services: Composite services CO-1 and CO-2, atomic service A-1, service cluster CLU-1
- b. Connectors: Conceptual Circular Association

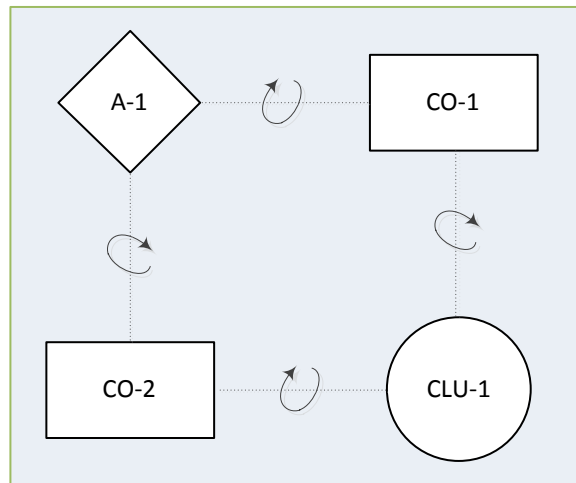

FIGURE 9: CONCEPTUAL ASSOCIATION DIAGRAM USING THE CIRCULAR PATTERN

CONCEPTUAL ASSOCIATION DIAGRAM COMPONENTS (FIGURE 10)

- a. Services: Parent composite service CO-1, atomic services A-1 and A-2
- b. Connector: Conceptual Hierarchical Association

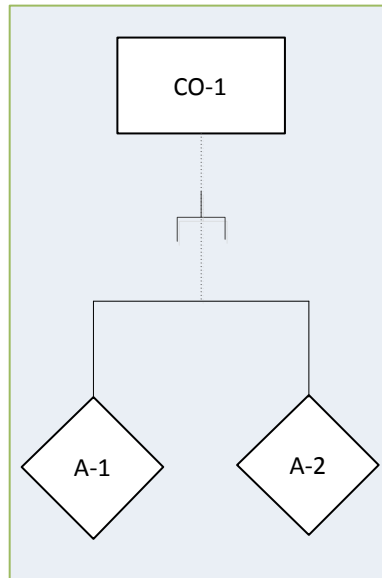

FIGURE 10: CONCEPTUAL ASSOCIATION DIAGRAM USING THE HIERARCHICAL PATTERN

CONCEPTUAL ASSOCIATION DIAGRAM COMPONENTS (FIGURE 11)

- a. Services: Atomic services A-1 and A-2, service cluster CLU-1, consumer CON-1, composite service CO-1
- b. Connectors: Conceptual Star Association

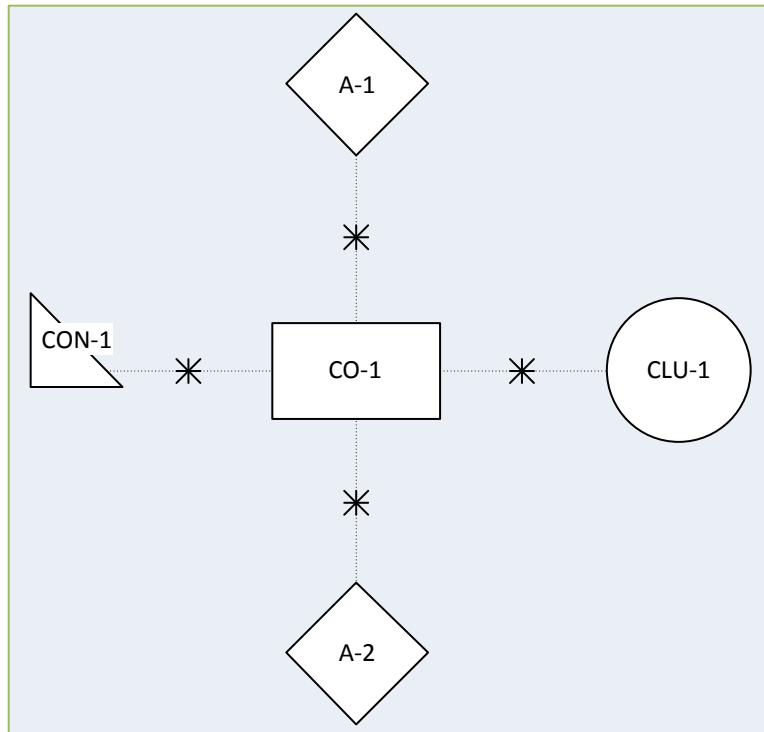

FIGURE 11: CONCEPTUAL ASSOCIATION DIAGRAM
USING THE STAR PATTERN

CONCEPTUAL ASSOCIATION DIAGRAM COMPONENTS (FIGURE 12)

- a. Atomic services A-1 and A-2, composite service CO-1, service cluster CLU-1, cloud of services CLO-1
- b. Conceptual network association connectors

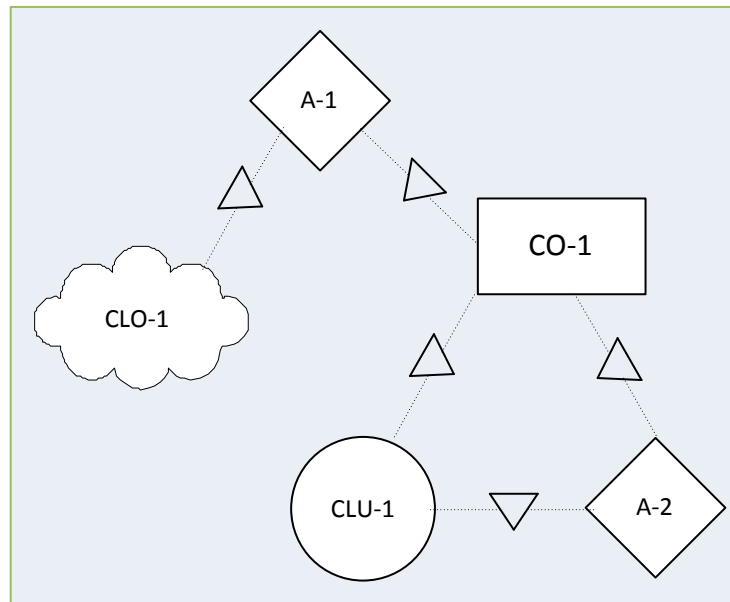

FIGURE 12: CONCEPTUAL ASSOCIATION DIAGRAM WITH NETWORK CONNECTORS AND A CLOUD OF SERVICES

CONCEPTUAL ASSOCIATION DIAGRAM COMPONENTS (FIGURE 13)

- a. Conceptual assets/services: Conceptual Trading Cloud, Conceptual ESB Composite Service, Conceptual Trading Consumer
- b. Connectors: Simple Conceptual Association

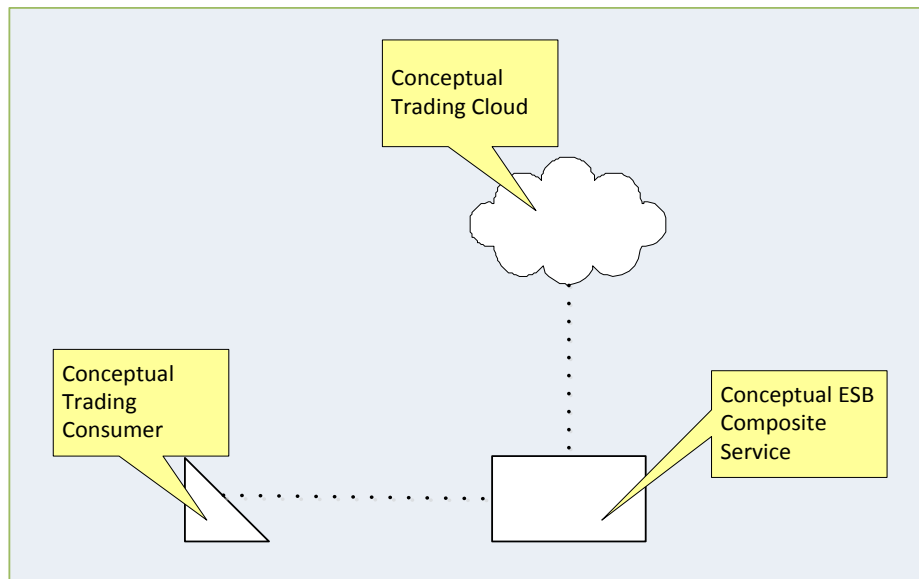

FIGURE 13: CONCEPTUAL ASSOCIATION DIAGRAM WITH SIMPLE CONNECTORS AND A CLOUD OF SERVICES

CONCEPTUAL ASSOCIATION DIAGRAM COMPONENTS (FIGURE 14)

- a. Conceptual Assets/Services: A cloud of services CLO-1, atomic service A-1, composite service CO-1, service cluster CLU-1
- b. Connectors: Conceptual Circular Association

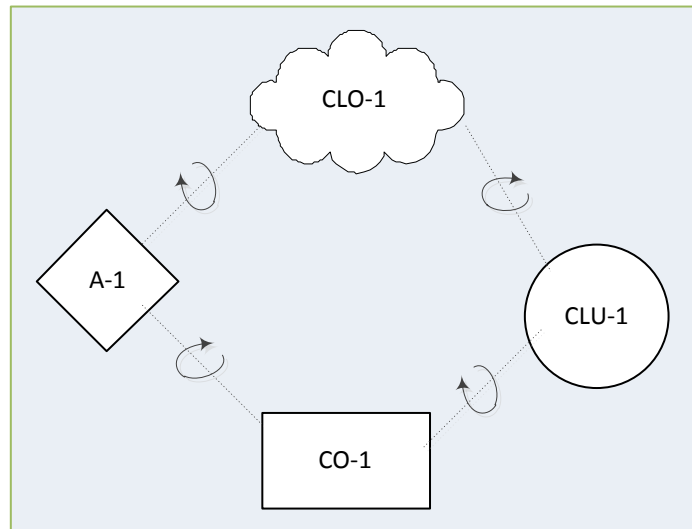

FIGURE 14: CONCEPTUAL ASSOCIATION DIAGRAM WITH CIRCULAR CONNECTORS AND A CLOUD OF SERVICES

CONCEPTUAL ASSOCIATION DIAGRAM COMPONENTS (FIGURE 15)

- a. IntraCloud Space contains:
 - i. Conceptual assets/services: service cluster CLU-1, atomic service A-1, composite service CO-1
 - ii. Connectors: Simple Conceptual Association
- b. ExtraCloud Space contains:
 - i. Conceptual assets/services: service cluster CLU-2, atomic service A-2, composite service CO-2
 - ii. Connectors: Conceptual Network Association
- c. IntraCloud and ExtraCloud spaces are linked by the Simple Conceptual Association connector

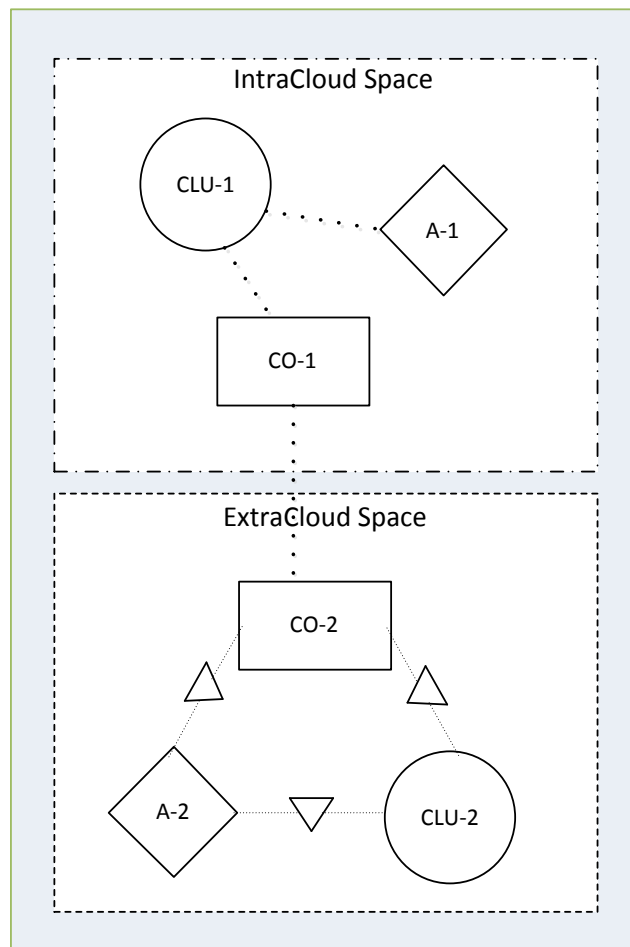

FIGURE 15: CONCEPTUAL ASSOCIATIONS DIAGRAM WITH INTRACLOUD AND EXTRACLOUD MODELING SPACES

CONCEPTUAL ASSOCIATION DIAGRAM COMPONENTS (FIGURE 16)

- a. Service Containment Space contains:
 - i. Services: Accounting Service Cluster
- b. Accounting Service Cluster contains:
 - i. Services: atomic services A-2, A-3, A-4, and composite services CO-1 and CO-2
 - ii. Connectors: Simple Conceptual Association
- c. Standalone atomic service A-1 linked by the Simple Conceptual Association connector to composite service CO-2

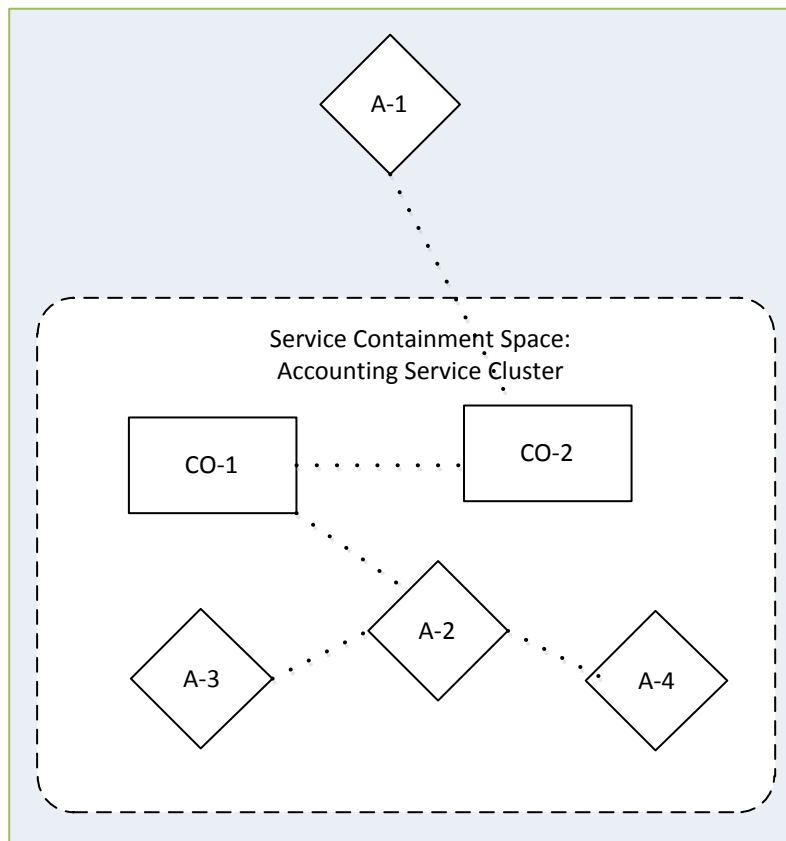

FIGURE 16: CONCEPTUAL ASSOCIATIONS DIAGRAM WITH A SERVICE CONTAINMENT SPACE

CONCEPTUAL ASSOCIATION DIAGRAM COMPONENTS (FIGURE 17)

- a. Organizational Boundary Space Cloud Provider Inc. contains:
 - i. Services: a cloud of services CLO-1
- b. Organizational Boundary Space Cloud Consumer Inc. contains:
 - i. Services: composite service CO-1 and atomic service A-1
 - ii. Connectors: Hierarchical Conceptual Association
- c. CLO-1 in Cloud Provider Inc. is linked to CO-1 in Cloud Consumer Inc. by the Simple Conceptual Association connector

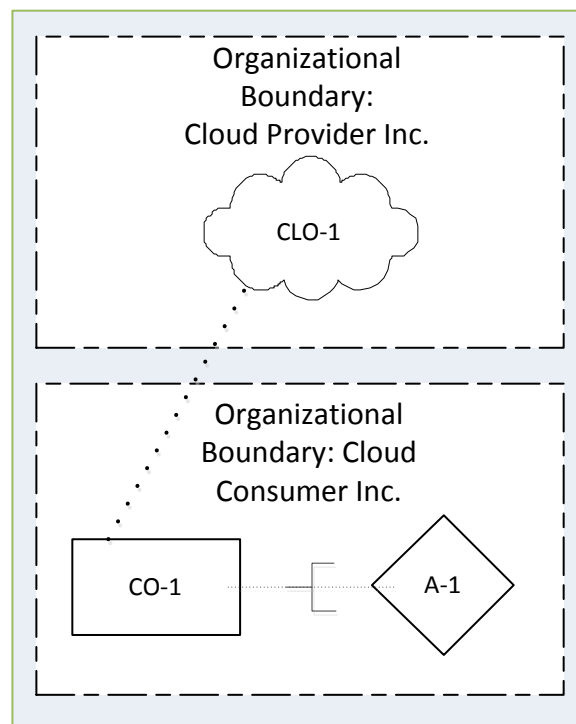

FIGURE 17: CONCEPTUAL ASSOCIATIONS DIAGRAM WITH ORGANIZATIONAL BOUNDARY SPACES